



NEW HOLLAND

C175 C185 C190 COMPACT TRACK LOADERS



- High-Productivity Super Boom® Design
- Track Flotation and Stability
- Best-in-Class Cab Comfort
- Easy Service Access and Attachment Changes
- Superior All-Around Visibility
- Comfortable, Easy-To-Operate Controls



BUILT AROUND YOU

LIFTING PERFORMANCE WITH THE UNMATCHED STABILITY OF TRACKS

New Holland compact track loaders combine the best performance advantages into one machine. You get the superior reach and lift capacity of the exclusive Super Boom® lift arm design along with the superior flotation, traction, and stability of tracks.

The patented Super Boom® design advantages

- Vertical lift linkage lifts the load up for outstanding forward reach and dump height
- Low center of gravity reduces tipping and increases lift capacity
- No rear frame towers allow for industry-leading rear visibility

The advantages of wide, durable tracks

- Improved traction in loose, sandy, or muddy conditions means you can push heavier loads
- Low ground pressure gives you maximum flotation and minimum soil disturbance
- A wide stance improves stability and offers a smoother ride
- Superior stability and traction allow for faster travel speeds, even over rough ground

Model C175 features a 12.6-inch track. Models C185 and C190 are available with two track options:

- 15.7-inch track—excellent flotation with additional traction
- 17.7-inch track—maximum flotation for sensitive turf



Unmatched Stability

New Holland Super Boom Compact Track Loaders give operators added confidence by providing a smooth ride over uneven terrain and inclines. This added stability, control, and confidence will keep your operators on schedule.

With Super Boom® vertical lift linkage, the higher you lift the load, the farther forward you reach, achieving outstanding dump height and reach.





Rated Operating Capacity	C175	C185	C190
50% Tipping, lbs (kg)	3,150 (1429)	3,643 (1652)	4,143 (1879)
35% Tipping, lbs (kg)	2,200 (998)	2,550 (1134)	2,900 (1315)
Tipping Load, lbs (kg)	6,300 (2858)	7,286 (3305)	8,286 (3758)
Dump clearance at full height, in (mm)	95.4 (2424)	103.4 (2627)	102.6 (2606)
Dump reach at full height, in (mm)	30.2 (768)	33.1 (840)	34.4 (874)



The ultimate high-performance machines for construction, utility, and grounds maintenance work. See one firsthand at your New Holland equipment dealer.

New Holland's Super Boom loader design provides excellent visibility out the large rear window. With a clear view out the large back window, operators can enjoy unobstructed visibility.

LESS COMPONENTS, PLUS FEWER MOVING PARTS EQUALS LOWER OPERATING COST

The rigid track frame with **fewer moving parts** reduces maintenance costs compared to suspension track systems.

Elevated Drive Sprocket increases component life by keeping the motor assembly out of material and moisture.

Rigid Frame with fewer moving parts means reduced cost of ownership compared to suspension track systems.

Easy Track Adjustment using a standard wrench and grease gun makes for quick and easy service.

Tapered Track Frame sheds mud and any other material to keep the track system clean.

Steel Embedded Track Cables and Cross Bars resist stretching while transferring the power of the drive train through the track and to the ground.

New Holland Crawler Technology incorporates metal face seals into rollers and idlers.

Crawler-Style Rollers help prevent de-tracking on inclines by using a larger inner diameter flange positioned between the track tabs.

Undercarriage shown is available on the C185 & C190.

Standard Two-Speed allows for greater speed variations to perform a wide variety of jobs.

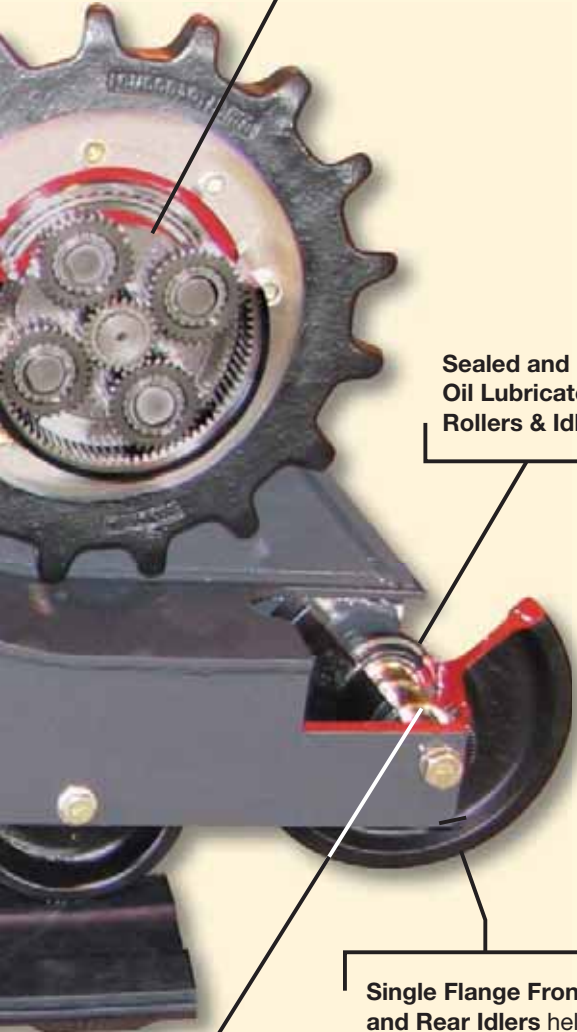

Sealed and Oil Lubricated Rollers & Idlers.

Single Flange Front and Rear Idlers help prevent de-tracking on inclines.

Large Brass Bushings distribute load better than bearings and offer resilience and longevity.



RUGGED, SIMPLE UNDERCARRIAGE DESIGN

Super Boom® compact track loaders are built with New Holland crawler technology to withstand the toughest conditions and the most challenging workloads. The undercarriage design is simple, yet rugged, giving you a stable ride over rough working surfaces.

Robust undercarriage components

- Strong, steel-belted rubber track
- Oil lubricated rollers and idlers
- Spring belt tensioner with grease gun adjustment

Standard, two-speed transmission at your command

- Low speed for pushing into a pile
- High speed for traveling at up to eight miles per hour

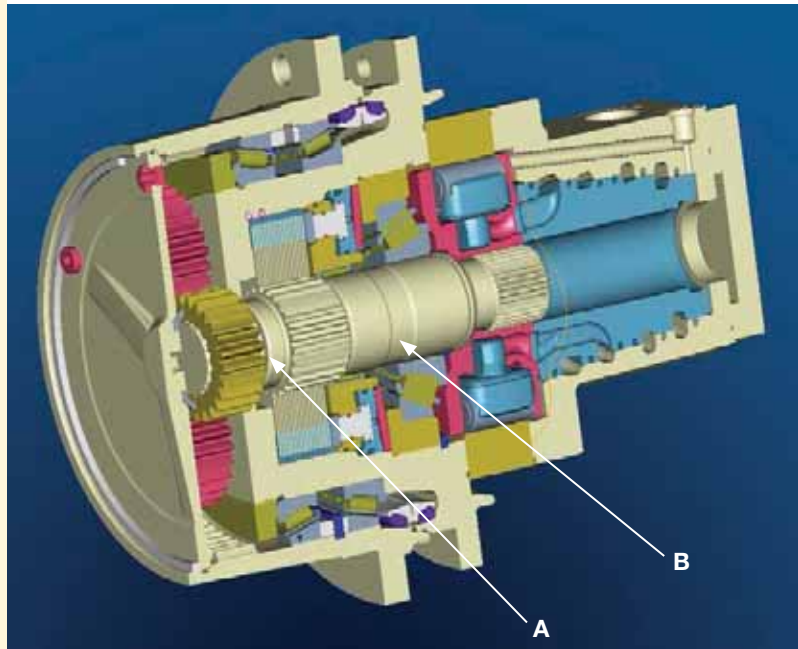

The combined gearbox (A) and motor (B) help maximize power output to the tracks. (C185 & C190 motor shown)

RESPONSIVE POWER AND FAST MAINTENANCE

New Holland compact track loaders allow you to power through tough conditions and deliver the fast response you need when performing multi-function tasks. Plus, fast maintenance makes it easier for your operators to stay on schedule.

Proven engine power

- Outstanding torque rise and horsepower
- Clean-burning engine with reduced emissions
- Excellent fuel economy
- High-cooling-capacity radiator

Quick-response hydraulics

- In-line hydrostatic pumps
- Smooth, quiet operation
- Fast ground speeds
- Quick cycle times
- Fast-action hydraulic cylinders reduce cycle times

Key support from the factory

- One-year or 2,000-hour Standard Full-Machine Warranty



Time-saving maintenance

New Holland compact track loaders lower your operating costs with fast, easy servicing. You can reach all major service points—even with the boom down. Rear access door provides quick and easy access to check engine oil, hydraulic oil, radiator coolant and fuel fill. Routine air filter maintenance is simple with an easy to reach, side-out element. If major repairs are ever necessary, the entire boom and cab assembly lifts up and tilts forward for unobstructed engine and transmission access.



New Holland Compact Track Loaders are US EPA Tier III certified for low emissions.

	C175	C185	C190
Horsepower			
Gross, hp (kW)	60 (45) @ 2900 rpm	82 (61) @ 2500 rpm	90 (67) @ 2300 rpm
Net, hp (kW)	56 (42) @ 2900 rpm	77 (57) @ 2500 rpm	83 (62) @ 2300 rpm
Operating Weight, lbs (kg)	7,535 (3418)*	9,100 (4128)**	9,820 (4454)**
Breakout Force			
Bucket, lbs (kg)	4,312 (1956)	7,670 (3479)	7,670 (3479)
Boom, lbs (kg)	3,003 (1362)	4,836 (2194)	6,229 (2825)

*Base unit plus full fuel tank, 165 lbs (75 kg) operator, 72" dirt and foundry bucket, and 12.6" (320 mm) track belt width
 **Base unit plus full fuel tank, 165 lbs (75 kg) operator, 84" dirt and foundry bucket, and 17.7" (450 mm) track belt width



A NEW POINT OF VIEW

The New Holland operator platform and optional deluxe cab enclosure expand your view of the world, while expanding your work site efficiency. You'll appreciate the added dimensions, visibility and comfort.

Superior visibility

- The sight lines rearward are the best in the industry due to the large rear window, sloping engine hood, and the lack of rear frame towers
- The boom's low front cross member provides an unobstructed view to the bucket's cutting edge
- The curved door of the enclosed cab features more glass for an outstanding view
- The deluxe cab enclosure includes an appropriately positioned windshield wiper for a clearer view in all conditions
- Front lights are positioned at the side of the cab to expand your forward view, especially to the upper corners, making it easier to position loads overhead and maneuver in low-clearance areas

A clean, quiet environment

- The cab sealing reduces dust infiltration
- Full-covering and noise-absorbing trim results in quieter interior sound levels
- An optional sound suppression package reduces noise levels by up to three decibels for an even quieter operator environment
- A heater/defroster kit and optional air conditioning allows you to control the climate in any weather
- A huge glass door opens a full 90 degrees for easy entry and exit
- A demolition door is available in lieu of a glass door for rugged working conditions

The see-through area on the cab roof provides a clear view to the bucket, even when it is positioned at full height.



Stay cool and refreshed by adding our optional Deluxe Cab with optional air conditioning or heat or both.





Adjustable contoured armrests and suspension seat allow operators to find a comfortable working position.



Optional pilot control precision

New Holland gives you the choice of standard mechanical controls or the optional pilot control system for added precision, comfort and productivity. The left joystick controls steering and forward/reverse travel while the right joystick controls the lift arm and attachment tilt. These low-effort joysticks, when combined with the suspension seat and the superior support of the long, contoured adjustable armrests, give you instant response with minimum movement for extremely precise control and less fatigue. The hand throttle is conveniently located to your right, allowing you to simultaneously drive with the left stick, while adjusting engine speed with your right hand or you can simply use the foot throttle.

COMFORT, CONVENIENCE, AND VERSATILITY

Operator efficiency begins with operator comfort, and operators get easy control and comfort without compromise in the New Holland operator platform.

The most comfortable, stable ride on the market

- A low center of gravity and a wider stance than competitive machines results in optimum stability and a smoother ride
- Contoured suspension seat provides deluxe operator comfort

Easy operation

- Conveniently placed controls require minimum effort
- Foot controls respond quickly and feature adjustable pedal position
- A fingertip control allows for easy changes between low and high speed
- State-of-the-art, electronic instrument control (EIC) panel is easy to read at a glance
- Spring-applied, hydraulic-released (SAHR) parking brakes engage with the push of a button
- Advanced Instrument Panel provides additional diagnostic tools, fault indicators, engine shut-down protection and security code lockout



MORE ATTACHMENTS, MORE VERSATILITY

Whatever you need to do – dig, lift, hammer, trench, plane, mow, sweep, rake or drill – there’s a New Holland attachment that will get the job done.

Built for multi-tasking

- Pick Up 'N Go™ universal attaching system allows for easy hookup to New Holland attachments as well as most competitive-brand attachments
- New Holland attachments are performance-matched to New Holland compact track loaders

Examples of hard-working attachments available

- Low Profile Bucket
- Dirt & Foundry Bucket
- Manure/Slurry Bucket
- Rock Bucket
- Brush Grapple
- Scrap Grapple
- Root Rake
- Heavy-duty Backhoe
- Mini Backhoe
- Skid Hoe
- Pallet Forks
- Concrete Claw
- Lift Boom
- Farm Forks/Grapple
- Silage Defacer
- Bale Handler
- Preparator
- Grading Rake
- Dozer Blade
- Push Broom
- Angle Broom
- Pick-up Broom
- Snow Blower
- Snow Blade
- Snow Bucket
- Trencher
- Rock Saw
- Cold Planer
- Vibrator Roller
- Concrete Chuter
- Silt Fence Installer
- Hydraulic Hammer
- Tree Shovel
- Log Grapple
- Tree Spade
- Chipper
- Earth Drill
- Rotary Mower
- Post Driver
- Post Puller
- And more!



Attachment changes without leaving the seat

Add the optional hydraulic mount plate and you can attach or remove buckets and attachments using a rocker switch from the operator compartment—no need to leave your seat!





C175 C185 C190 Dimensions & Bucket Selection

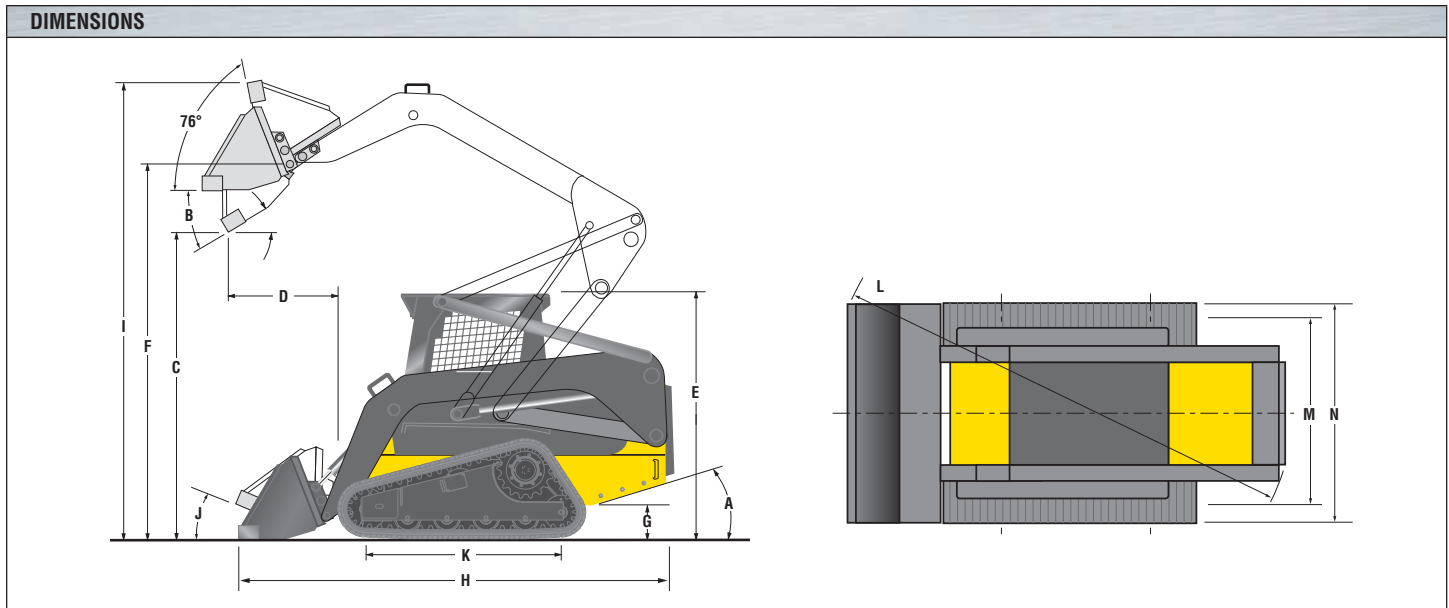

	C175		C185		C190	
A. Angle of departure	32°		29°		28°	
B. Dump angle (maximum)	43°		45°		45°	
C. Dump height (SAE), in (mm)	95.4	(2,424)	103.4	(2,627)	102.6	(2,606)
D. Dump reach @ maximum height (SAE), in (mm)	30.2	(768)	33.1	(840)	34.4	(874)
E. Height, in (mm)	75.9	(1,929)	80.1	(2,036)	80.1	(2,036)
F. Height to hinge pin, in (mm)	119.7	(3,041)	128.3	(3,258)	127.4	(3,237)
G. Ground clearance, in (mm)	8.3	(212)	10.4	(264)	10.4	(264)
H. Length with bucket, in (mm)	129.7	(3,293)	141.2	(3,587)	148.2	(3,764)
I. Operating height (maximum), in (mm)	146.4	(3,717)	152	(3,861)	152.7	(3,878)
J. Rollback angle (at carry position)	35°		36°		39°	
K. Track on ground length, in (mm)	54.9	(1,394)	64.7	(1,643)	64.7	(1,643)
L. Circle clearance, in (mm)	138.9	(3,528)	158.2	(2,164)	161	(4,089)
M. Track gauge, in (mm)	58	(1,472)	64.8	(1,647)	64.8	(1,647)
N. Width, in (mm)	70.6 (1,792) with 12.6 (320) track		82.6 (2,097) with 17.7 (450) track		82.6 (2,097) with 17.7 (450) track	

Equipped with Dirt & Foundry Buckets

	BUCKETS			SAE Heaped Capacity		SAE Struck Capacity		Weight	
	C175	C185	C190	ft ³	(m ³)	ft ³	(m ³)	lb	(kg)
72" (1829 mm) Dirt/Foundry	X			16.7	(.45)	12.7	(.34)	390	(177)
78" (1981 mm) Dirt/Foundry	X			18.4	(.52)	13.8	(.39)	435	(197)
84" (2134 mm) Dirt/Foundry		X	X	21.9	(.62)	18	(.51)	450	(204)
72" (1829 mm) Low Profile (heavy duty)	X			14.6	(.41)	12.5	(.35)	501	(227)
84" (2134 mm) Low Profile (heavy duty)		X	X	17.3	(.48)	12.4	(.35)	552	(250)
72" (1829 mm) Low Profile (extended)	X			17.1	(.48)	12.2	(.35)	477	(216)
78" (1981 mm) Low Profile (extended)	X			18.6	(.52)	13.2	(.37)	502	(227)
84" (2134 mm) Low Profile (extended)		X	X	20.1	(.57)	14.1	(.40)	608	(276)
72" (1829 mm) Light Material	X			23.7	(.65)	19.0	(.52)	435	(197)
84" (2134 mm) Light Material	X	X	X	27.9	(.79)	22.3	(.64)	500	(227)
72" (1829 mm) Manure/Fertilizer	X			19.1	(.54)	15.5	(.42)	465	(211)
84" (2134 mm) Manure/Fertilizer		X	X	22.5	(.64)	18.2	(.52)	540	(245)

C175 C185 C190 Specifications

CAPACITIES			
	C175	C185	C190
Cooling system, gal (L)	3 (11.4)	3 (11.4)	4.5 (17)
Engine crankcase (w/filter), qt (L)	8.4 (8.0)	9 (8.5)	11.6 (11)
Fuel tank, gal (L)	16.3 (61.7)	22.9 (86.7)	26.5 (100)
Hydraulic oil system, gal (L)	8.6 (32.6)	15 (56.8)	15 (56.8)

PERFORMANCE			
	C175	C185	C190
OPERATING WEIGHT:			
SAE, lbs (kg)	7,535 (3418)*	9,100 (4128)**	9,820 (4454)**
OPERATING LOAD:			
50% of tipping load, lbs (kg)	3,150 (1429)	3,643 (1652)	4,143 (1879)
35% of tipping load, lbs (kg)	2,200 (998)	2,550 (1157)	2,900 (1315)
Hydraulic limitation, lbs (kg)	2,200 (998)	2,850 (1293)	3,700 (1678)
TIPPING LOAD:			
Without weights per SAE J-732, lbs (kg)	6,300 (2858)	7,286 (3305)	8,286 (3758)
BREAKOUT FORCE:			
SAE Bucket breakout force, lbs (kg)	4,312 (1,956)	7,670 (3,479)	7,670 (3,479)
SAE Boom breakout force, lbs (kg)	3,003 (1,362)	4,836 (2,194)	6,229 (2,825)
CYCLE TIMES:			
Raising time (with SAE operating load), sec	3.1	2.8	3.3
Dumping time (with SAE operating load), sec	2.3	1.8	1.8
Lowering time (empty), sec	2.1	2.5	3.1
Retract time (empty), sec	1.5	1.6	1.6
Total boom-cycle time, sec	9	8.7	9.8
GROUND SPEED MAX:			
Low Range, mph (km/h)	5.6 (9)	5.4 (8.7)	5.1 (8.2)
High Range, mph (km/h)	7.4 (12)	8.6 (13.8)	8.0 (12.9)

*Base unit plus full fuel tank, 165 lbs (75 kg) operator, 72" dirt and foundry bucket, and 12.6" (320 mm) track belt width

**Base unit plus full fuel tank, 165 lbs (75 kg) operator, 84" dirt and foundry bucket, and 17.7" (450 mm) track belt width

UNDERCARRIAGE			
	C175	C185	C190
System	High drive offset tread pattern	High drive offset tread pattern	High drive offset tread pattern
Idlers / Rollers per side	2 / 3	2 / 4	2 / 4
Ground Pressure:			
12.6" (320 mm) belt, psi	5.4	—	—
15.7" (400 mm) belt, psi	—	4.5	4.8
17.7" (450 mm) belt, psi	—	4.0	4.3

POWERTRAIN			
	C175	C185	C190
Hydrostatic piston type pumps displacement, in ³ (cc)	2.48 (40.6)	2.81 (46)	2.81 (46)
Hydrostatic axial piston type motors at maximum displacement, in ³ (cc)	3.1 (50.8)	—	—
Hydrostatic radial piston type motors with maximum displacement, in ³ (cc)	—	18.9 (310)	18.9 (310)

C175 C185 C190 Specifications

ELECTRICAL			
	C175	C185	C190
Alternator	55 amp, solid-state rectifier and regulator	95 amp, solid-state rectifier and regulator	95 amp, solid-state rectifier and regulator
Battery	12-volt 650 CCA @ 0°F (-18°C) maintenance free	12-volt 1,125 CCA @ 0°F (-18°C) maintenance free	12-volt 1,125 CCA @ 0°F (-18°C) maintenance free
System protection	30 amp circuit breaker	30 amp circuit breaker	30 amp circuit breaker

INSTRUMENTS: Hour meter, voltage alarm, hydraulic oil temperature light and alarm, coolant temperature light and alarm, fuel gauge, transmission charge pressure light and alarm, engine oil pressure light and alarm, seat belt light, engine malfunction light and alarm, transmission filter restriction light and alarm, parking brake reminder light

ENGINE			
	C175	C185	C190
Manufacturer	ISM	FPT	FPT
Model number	N844LT	F5C E5454	F4G E9454
Air cleaner	Dual stage, dry element filter	Dual stage, dry element filter	Dual stage, dry element filter
Bore and stroke, in (mm)	3.3 x 3.9 (84 x 100)	3.89 x 4.09 (99 x 104)	4.1 x 5.2 (104 x 132)
Number of cylinders	4	4	4
Displacement, in ³ (L)	135 (2.2)	195 (3.2)	274 (4.5)
Fuel Diesel	Diesel	Diesel	Diesel
HORSEPOWER:			
Gross, hp (kW)	60 (45)	82 (61)	90 (67)
SAE Net, hp (kW)	56 (42)	77 (57)	83 (62)
SPEEDS:			
Fast, no load, rpm	3140 +/- 40	2675 +/- 75	2415 +/- 60
Idle, no load, rpm	1200 +/- 50	1075 +/- 50	1075 +/- 75
Peak torque, lb-ft (N•m)	128 (173) @ 1,700 rpm	229 (310) @ 1,400 rpm	288 (390) @ 1,300 rpm
Torque rise	20%	32%	40%

HYDRAULICS			
	C175	C185	C190
BOOM CYLINDERS:			
Make	New Holland double acting	New Holland double acting	New Holland double acting
Bore and stroke, in (mm)	2.5 x 21.25 (63.5 x 540)	2.5 x 24.06 (63.5 x 611)	2.75 x 24.06 (70 x 611)
Rod size, in (mm)	1.38 (35.1)	1.5 (38.1)	1.75 (44.5)
BUCKET CYLINDERS:			
Make	New Holland double acting	New Holland double acting	New Holland double acting
Bore and stroke, in (mm)	2.25 x 17.88 (57.2 x 454.2)	2.5 x 17.6 (64 x 447)	2.5 x 17.6 (64 x 447)
Rod size, in (mm)	1.25 (31.8)	1.25 (31.8)	1.25 (31.8)
Control	3-spool open center	3-spool open center	3-spool open center
Filtration	5-micron, spin-on filter	6-micron, spin-on filter	6-micron, spin-on filter
Hydraulic pump, gpm	Gear type 17.2	Gear type 21.0	Gear type 21.9
High flow hydraulics (if equipped), gpm	25.5	35.8	37.3
Oil reservoir, gal (L)	3.9 (14.8)	5 (18.9)	5 (18.9)
Relief pressure setting, psi (bar)	2,500 (172)	3,050 (210)	3,050 (210)



C175 C185 C190 Base & Optional Equipment

BASE EQUIPMENT

CONTROLS

- Hand/Foot Controls

ENGINE

- 4 Cylinders Turbocharged
- Block heater (C175)
- Dry Dual Element Air Cleaner
- Electric Key Shutoff
- Grid Heater Cold Start Aid (C185 & C190)
- ISM N844LT (C175)
- FPT F5C E5454 (C185)
- FPT F4G E9454 (C190)
- Quick-start glow plugs (C175)

HYDRAULICS

- Boom Hydraulics
- Flat-face couplers
- Full-flow Hydraulic Cooler
- Gear-type, 17.2 gpm (C175)
- Gear-type, 21 gpm (C185)
- Gear-type, 21.9 gpm (C190)
- Three-spool, open-center control valve

TRANSMISSION

- Variable displacement axial piston pumps, axial piston motors (C175)
- Variable displacement axial piston pumps, radial piston motors (C185 & C190)

ELECTRICAL

- 12-volt system
- 30-amp circuit breaker
- 55-amp alternator (C175)
- 95-amp alternator (C185 & C190)
- Air cleaner restriction light and alarm
- Coolant temperature light and alarm
- Engine oil pressure light and alarm
- Fuel gauge
- Hour meter
- Hydraulic oil temperature light and alarm
- Parking brake reminder light
- Seat belt light

- Single battery with 650 CCA (C175)
- Single battery with 1,125 CCA (C185 & C190)
- Transmission charge pressure light and alarm
- Transmission filter restriction light and alarm
- Voltage alarm

LIGHTING

- Worklights (4 front headlights & 3 rear lights including supplemental lighting for working in limited light conditions)

SERVICE

- 50-hour lube interval
- Boom and cab tilting feature
- Lift-up seat pan (no tools required)
- Low-mounted fuel fill
- Rear engine door/top engine cover
- Removable side engine panels (no tools required)

SAFETY

- Back-up alarm
- Horn
- Hydraulic lockout
- Manual, in-cab boom lockouts
- Retractable seatbelt
- ROPS operator area
- Spring Applied Hydraulic Release (SAHR) brake

VANDAL PROTECTION

- Enclosed fuel cap
- Enclosed hydraulic fill
- Lockable engine cover and side panels

ACCESSORIES

- 12-volt accessory power plug
- Armrests
- Cab headliner
- Suspension seat
- Rotating Beacon Pre-Wired (Rotating Beacon - Optional)
- Advanced instrument panel with security lockout
- Remote jump-start terminal

OPTIONAL EQUIPMENT

ACCESSORIES

- 15.7 inch track belt (C185 & C190)
- Air conditioning
- Bucket spill guard
- Bucket tooth kit
- Cab enclosure
- Cab jack kit
- Cab side window kit
- Decal kits
- Demolition kit
- Fire extinguisher bracket kit
- Floor cover plates
- Four-way flashers/warning lights
- Hand controls
- Heater/defroster
- High-flow hydraulics
- Hydraulic mount plate
- Pilot controls
- Rearview mirror
- SMV signs
- Three-inch seatbelt
- Top window
- Turn signals
- Warning Beacon (pre-wiring standard)

BUCKETS AND ATTACHMENTS

- 72" Dirt/Foundry (C175)
- 78" Dirt/Foundry (C175)
- 84" Dirt/Foundry (C185 & C190)
- 72" Low Profile (heavy duty) (C175)
- 84" Low Profile (heavy duty) (C185 & C190)
- 72" Low Profile (extended) (C175)
- 78" Low Profile (extended) (C175)
- 84" Low Profile (extended) (C185 & C190)
- 72" Light Material (C175)
- 84" Light Material (C185 & C190)
- 72" Manure/Fertilizer (C175)
- 84" Manure/Fertilizer (C185 & C190)
- Pallet forks



**SUPER BOOM®
COMPACT TRACK
LOADERS**

C175

Operating Weight
7,535 lbs (3418 kg)

Horsepower
Gross 60 hp (45 kW) @ 2,900 rpm

Rated operating capacity
50% tipping 3,150 lbs (1429 kg)
35% tipping 2,200 lbs (998 kg)

C185

Operating Weight
9,100 lbs. (4128 kg)

Horsepower
Gross 82 hp (61 kW) @ 2,550 rpm

Rated operating capacity
50% tipping 3,643 lbs (1652 kg)
35% tipping 2,500 lbs (1134 kg)

C190

Operating Weight
9,820 lbs. (4454 kg)

Horsepower
Gross 90 hp (67 kW) @ 2,300 rpm

Rated operating capacity
50% tipping 4,143 lbs (1879 kg)
35% tipping 2,900 lbs (1315 kg)

World Class Products Demand World Class Dealers

The purchase of a New Holland Construction machine is just the beginning of our relationship together. Consider your experienced New Holland Construction Equipment dealer as your local partner in productivity. Assistance in selecting the right model for your operation and developing an affordable leasing or financing plan through CNH Capital are just a few advantages your local dealer can provide.

Your New Holland Construction dealer's full service capabilities bring you responsive support with genuine New Holland parts and all makes coverage. More importantly, we are there wherever and whenever you need us with our fully equipped service vehicles. From customized maintenance programs to professional operator and technical training, our factory-trained service and parts experts are there to assist you with any of your equipment support needs.

Your business deserves nothing less than world class product, supported by a world class business partner. That's your New Holland Construction Equipment dealer—your partner in productivity.



New Holland Construction Equipment is backed with a **1-Year/Unlimited Hour Standard Warranty.**

Use our dealer locator at www.newholland.com to find the dealer nearest you.



New Holland Construction
245 E. North Avenue
Carol Stream, IL 60188-2021
866-726-3396 Toll Free
630-260-4000
630-260-4304 Fax



Design, materials and/or specifications are subject to change without notice and without liability therefor. Specifications are applicable to units sold in Canada, the United States, its territories and possessions, and may vary outside these areas.

© 2008 CNH America LLC. All rights reserved. New Holland is a trademark of CNH America LLC. Any trademarks referred to herein, in association with goods and/or services of companies other than CNH America LLC, are the property of those respective companies.



Safety begins with a thorough understanding of the equipment. Always make sure you and your operators read the Operator's Manual before using the equipment. Pay close attention to all safety and operating decals and never operate machinery without all shields, protective devices and structures in place.

STOCK #NHC11030802 • 1108XX • XXX • PRINTED IN U.S.A.



Printed on recycled paper

www.newholland.com